

Caxtool Kft.
6791 Szeged, Dorozsmai út 157. EU
+36 62 254 826
+36 30 565 1812
d.zanocz@caxtool.hu
info@caxtool.hu

Adószám: 12871856-2-06
Adószám: HU 12871856
Bankszámla száma: 57600101-11102986
SWIFT (BIC): TAKBHUHB
IBAN: HU65 57600101 11102986 00000000
cégjegyzékszám: 06-09-014002
info:

Képgyűjtemény

Fiber lézervágó berendezés

CAXTC_Accurl_Genius_3015_1kW_1.0 fiber lézervágó berendezés / Fiber cutting machine



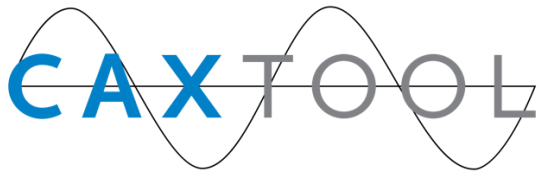

Caxtool Kft.
6791 Szeged, Dorozsmai út 157. EU
+36 62 254 826
+36 30 565 1812
d.zanocz@caxtool.hu
info@caxtool.hu

Adószám: 12871856-2-06
Adószám: HU 12871856
Bankszámla száma: 57600101-11102986
SWIFT (BIC): TAKBHUHB
IBAN: HU65 57600101 11102986 00000000
cégjegyzékszám: 06-09-014002
info:

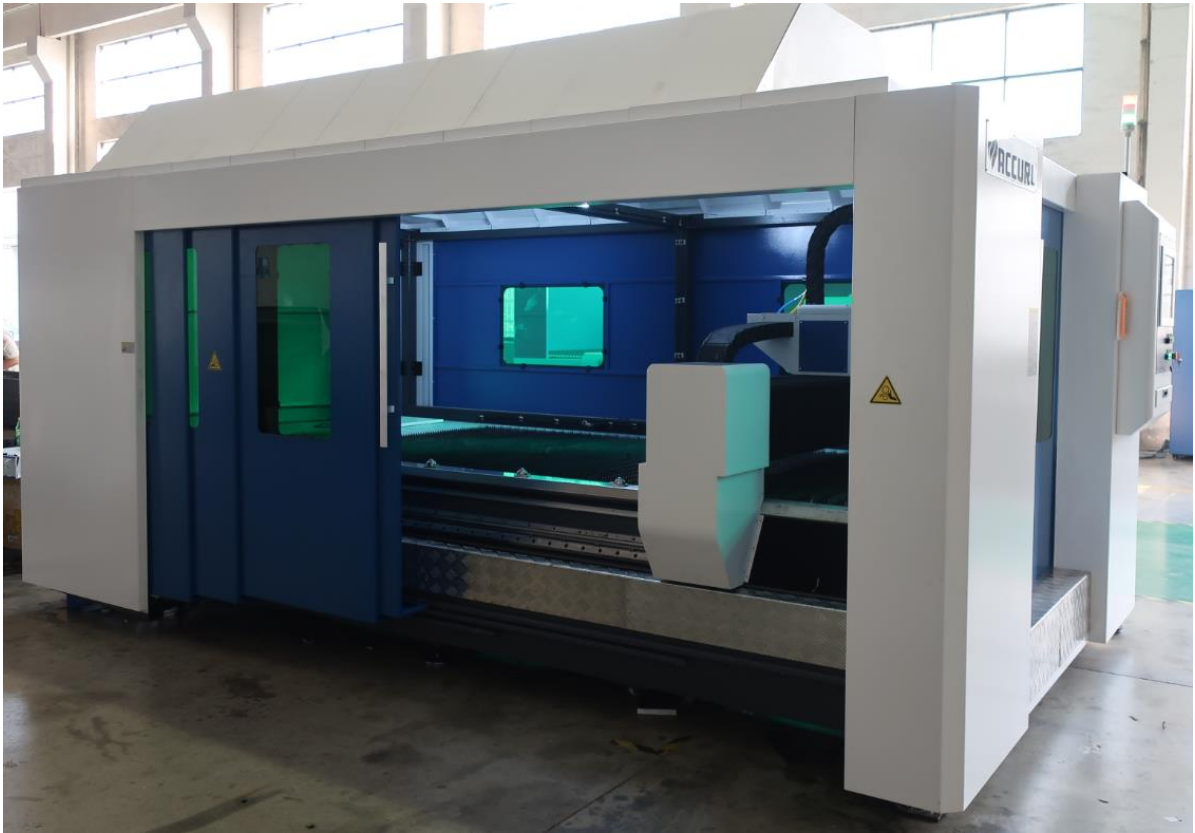

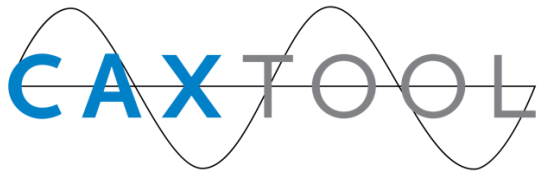

Caxtool Kft.
6791 Szeged, Dorozsmai út 157. EU
+36 62 254 826
+36 30 565 1812
d.zanocz@caxtool.hu
info@caxtool.hu

Adószám: 12871856-2-06
Adószám: HU 12871856
Bankszámla száma: 57600101-11102986
SWIFT (BIC): TAKBHUHB
IBAN: HU65 57600101 11102986 00000000
cégjegyzékszám: 06-09-014002
info:

FULLY ANNEALED FRAME

Accurl steel frames under go annealing at over 600° to relieve stress. They are built to last years of heavy use without distortion.

Auto changing pallet system allows over 2500kg loading weight.



OPTIMIZED BASE FRAME

- Very stiff and stable base frame
- Eight(8) zone & ducted exhaust system
- Dual synchronized twin servo motor drive system
- Helical rack & slant pinion drive system enables very smooth movements.

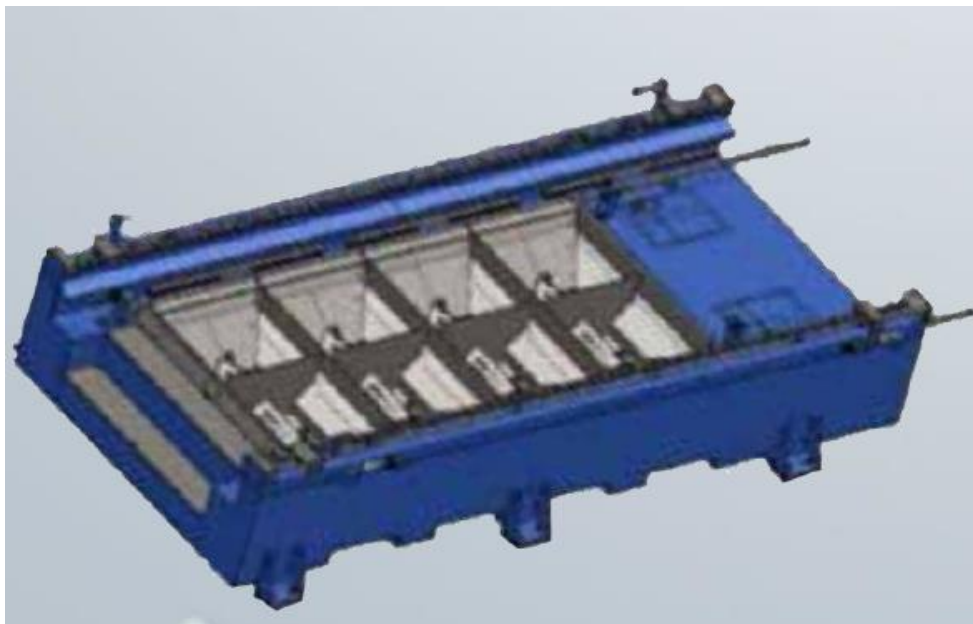

UITRALIGHT-WEIGHT GANTRY STRUCTURE

•Light-weight cutting head assembly (Total weight 130 lbs) is designed for high dynamic movement, lowering the Tool Center Point to keep the cutting head from losing accuracy that is caused by whipping or drifting during high speed accel/decel movement

CAST ALUMINIUM GANTRY

- ACCURL®s high tech aluminium cross beam is cast in a specially manufactured 10-tonne steel mould.
- This allows better rigidity at 50% of the weight of traditional iron gantries, allowing higher acceleration with reduced inertia.



YASKAWA SERVO MOTORS & DRIVES

- servo motors and drives from YASKAWA.
- High-speed EtherCAT communication
- Highly dynamic behaviour
- Brushless three-phase motors
- Flexible motor type selection



FUME EXTRACTION SYSTEM

- Efficient fume extraction by means of shutters which are controlled in accordance with cutting head position results in more efficient use of the filtration system.
- Therefore a smaller lower cost system can be used.the system consists of six fume extraction zones (as seen below).
- Smaller air flow from the dust collector
- Low electrical consumption
- Smoke and dust free machining area

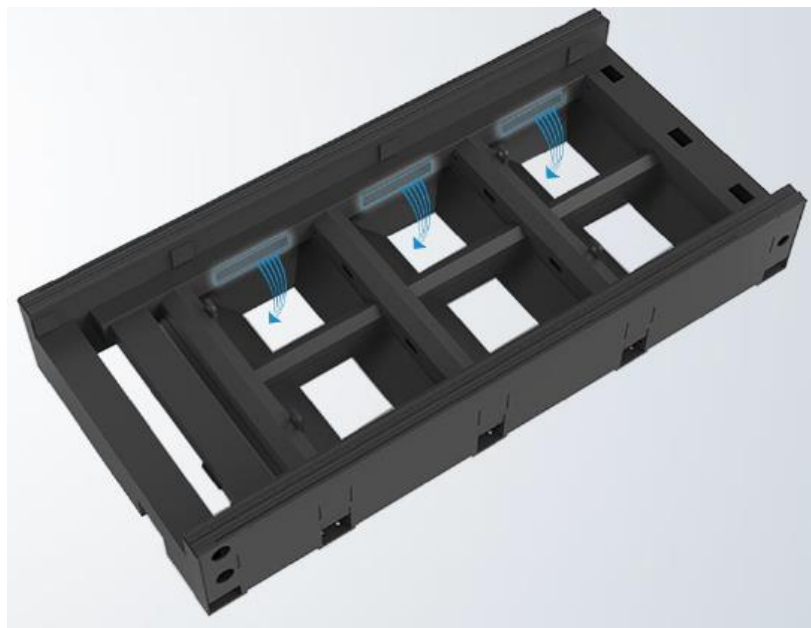

DUST EXTRACTION SYSTEM

- The fumes extraction or aspiration system for the treatment of vapors and fumes derived from laser cutting, consisting of:
- Filter plates with automatic compressed air cleaning cycle
- Integrated silencer
- Elimination of dust, particles and harmful fumes generated during cutting:
- Intelligent control by Siemens
- Self cleaning and Easy Disposal
- Free contacts for external control
- Integrated fan
- Dust load dependent automatic filter cleaning
- Siemens CPU and PTFE membrane filter cartridges
- This system is used to filter dry dust from industrial leaks, in accordance with VDI guidelines 3677, paragraph 4. The filter elements use compact porous filters.
- In many countries it is forbidden to circulate filtered air during the cutting of stainless steel (CrNi). Therefore, it is recommended that the user install air ducts to the outside.

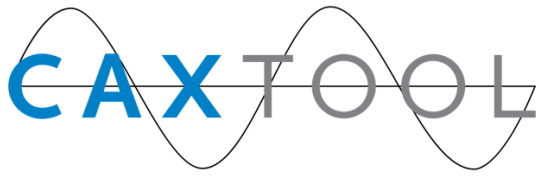

Caxtool Kft.
6791 Szeged, Dorozsmai út 157. EU
+36 62 254 826
+36 30 565 1812
d.zanocz@caxtool.hu
info@caxtool.hu

Adószám: 12871856-2-06
Adószám: HU 12871856
Bankszámla száma: 57600101-11102986
SWIFT (BIC): TAKBHUHB
IBAN: HU65 57600101 11102986 00000000
cégjegyzékszám: 06-09-014002
info:



Raytools BM111 Series 3.3KW Auto-Focusing Laser Cutting Head



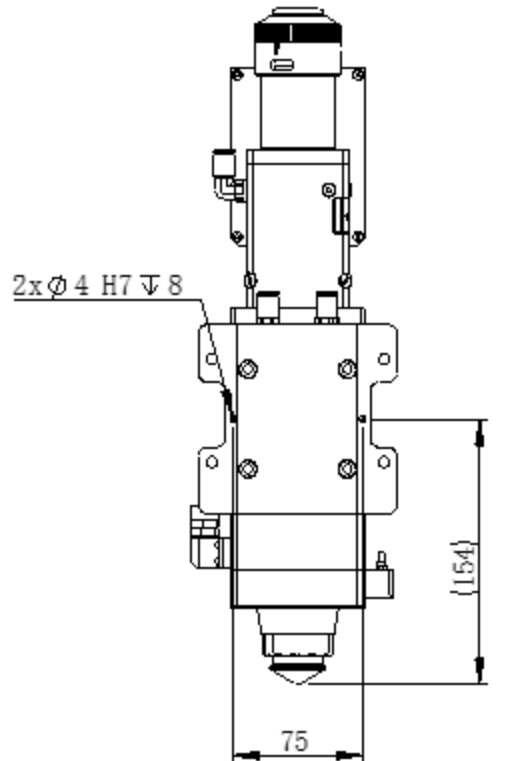
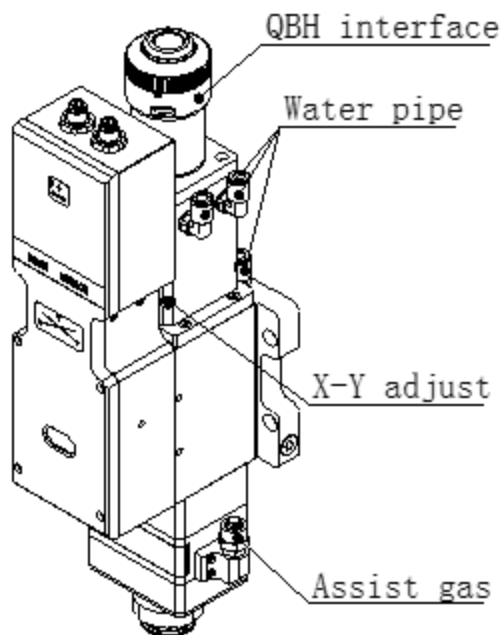
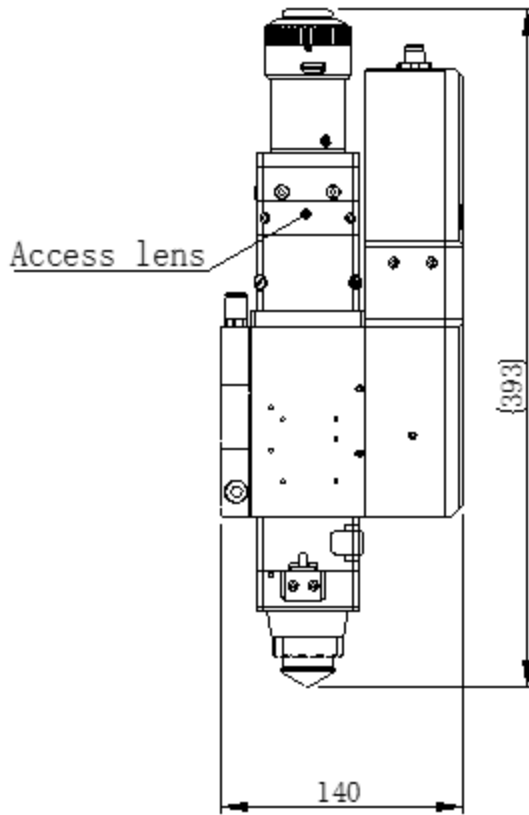
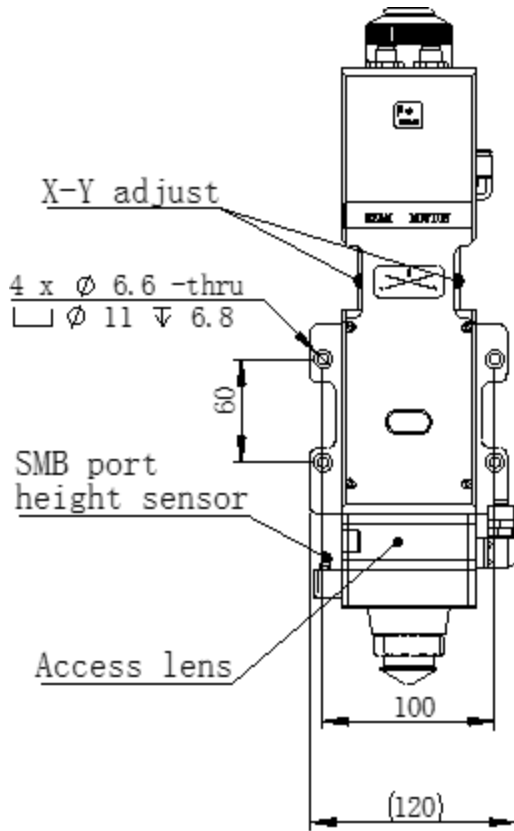

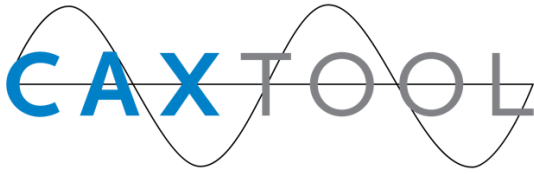

Caxtool Kft.
6791 Szeged, Dorozsmai út 157. EU
+36 62 254 826
+36 30 565 1812
d.zanocz@caxtool.hu
info@caxtool.hu

Adószám: 12871856-2-06
Adószám: HU 12871856
Bankszámla száma: 57600101-11102986
SWIFT (BIC): TAKBHUHB
IBAN: HU65 57600101 11102986 00000000
cégjegyzékszám: 06-09-014002
info:

The product has built-in motor drive unit through the linear driver and the focusing lens can automatically change the position in the range of 22mm.

The user can set the focus continuously through the program to complete the rapid perpiercing of thick sheets or other different thickness and material sheets.

The product can be equipped with D30 lens group to integrate the light beam.

The optimization of optical design and the design of water-cooled allows laser heads stably and chronically to work at high power lasers.

- Optimized optical configuration and smooth and efficient airflow design.
- Auto focus ranges +9~-14mm, accuracy is 0.05mm.
- Can be equipped with the D30 lens group, the maximum fiber input power is 3.3KW.
- Maximum acceleration of focus lens drive 10m/s², maximum speed 10m/min.
- Adds an upper protective lens to the collimator, minimizing the risk of contamination of the collimator.
- Drawer-type of lens mount, quick and easy access to the cover glass.
- With a variety of optical interfaces, can be adapted with a variety of fiber lasers.

Power Rating	≤3.3KW
Clear Aperture	28mm
Collimator Focal length	100mm
Focusing Focal length	125mm/155mm/200mm
Collimating protective glass	φ24.9mm*1.5mm
Focus protective glass	φ27.9mm*4.1mm
Auto focus range	+10~-12mm
Assist gas Pressure	≤30bar
Weight	~6.5kg

FIBER LASER RESONATOR IPG

•The fiber laser resonator is a separate unit unattached to the cutting machine; this facilitates the design of laser cutters to deal with high speed cutting of thin materials and highquality cutting of thick materials. The unit contains the high stability resonator, kinetically suspended. The laser resonator includes a communication system featuring the control unit and a closed cooling circuit.

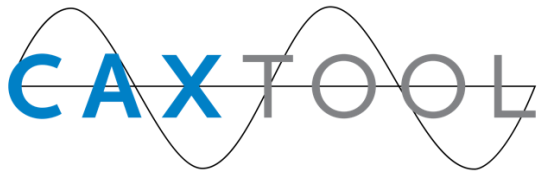

Caxtool Kft.
6791 Szeged, Dorozsmai út 157. EU
+36 62 254 826
+36 30 565 1812
d.zanocz@caxtool.hu
info@caxtool.hu

Adószám: 12871856-2-06
Adószám: HU 12871856
Bankszámla száma: 57600101-11102986
SWIFT (BIC): TAKBHUHB
IBAN: HU65 57600101 11102986 00000000
cégjegyzékszám: 06-09-014002
info:

Features of the IPG equipment are as follows:

- Direct control of all the fiber laser functions
- Synchronized control of the lasersource
- Overall power control
- High speed perforation
- Edge machining function
- Cutting data library
- High speed fiber laser cutting
- Wall-plug Efficiency >40%
- Cost-effective CuttingSystem
- Maintenance-free Operation
- Fiber Delivery 50, 100, 150or 200µm
- CW Output Power up to 20 kW @ Workpiece
- New fiber block design with 3x increase in damage power threshold, resulting in increasedreliability

COMMITMENTTO QUALITY

- Accurl assemble their machines tothe strictest qualitystandards, utilizing many tools and methods to ensure accuracy all throughout their process.
- The use of an interferometer records the machines X and Y axis movement during cutting to ensure accuracy. Adjustments are made to ensure machine is precisely tuned before shipment.



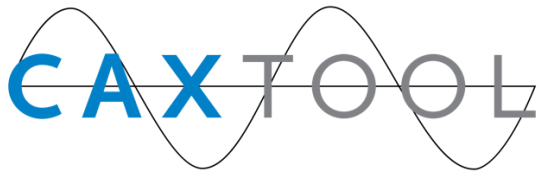

Caxtool Kft.
6791 Szeged, Dorozsmai út 157. EU
+36 62 254 826
+36 30 565 1812
d.zanocz@caxtool.hu
info@caxtool.hu

Adószám: 12871856-2-06
Adószám: HU 12871856
Bankszámla száma: 57600101-11102986
SWIFT (BIC): TAKBHUHB
IBAN: HU65 57600101 11102986 00000000
cégjegyzékszám: 06-09-014002
info:

- A Marble test is performed to measure the X and Y axis, calculating any necessary adjustments to ensure perfect level and alignment along length of machine.



- A collimator is run along the full length of the guide rail, testing for straightness. Adjustments are made as required to ensure linear accurate linear accuracy.

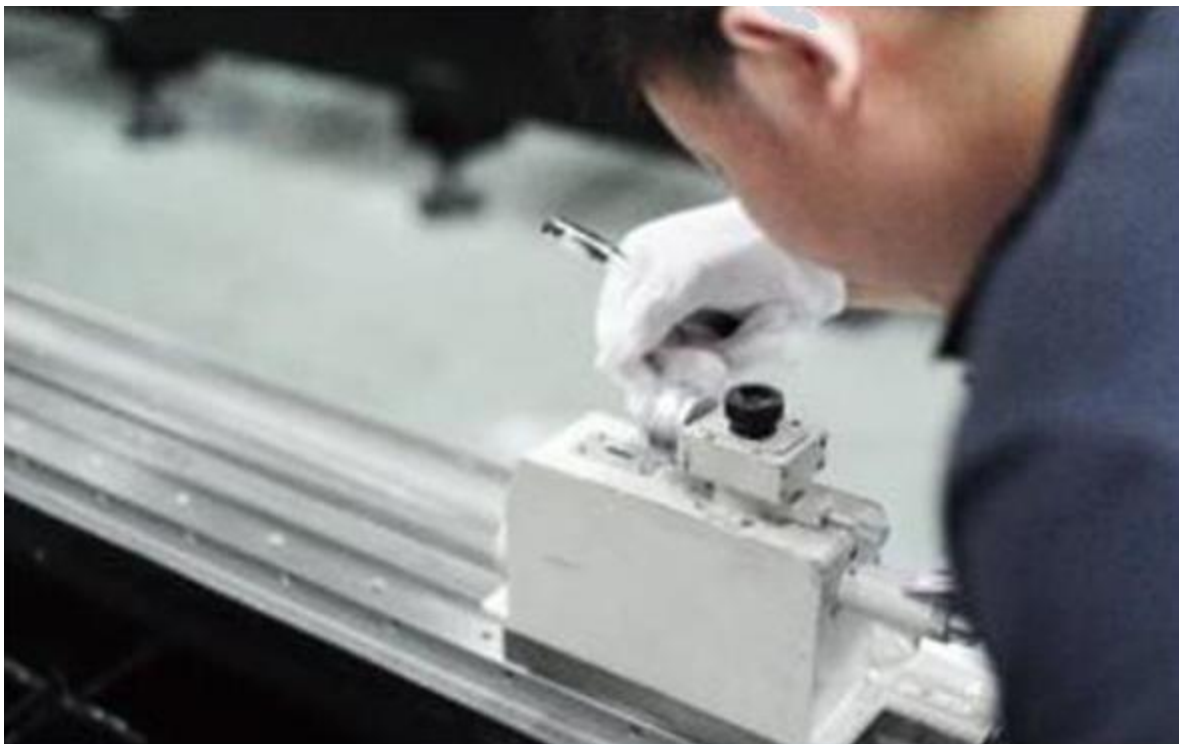

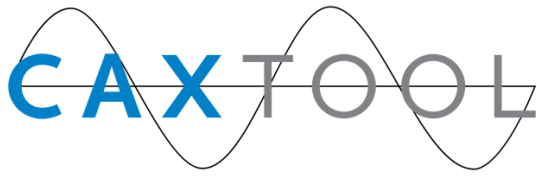

Caxtool Kft.
6791 Szeged, Dorozsmai út 157. EU
+36 62 254 826
+36 30 565 1812
d.zanocz@caxtool.hu
info@caxtool.hu

Adószám: 12871856-2-06
Adószám: HU 12871856
Bankszámla száma: 57600101-11102986
SWIFT (BIC): TAKBHUHB
IBAN: HU65 57600101 11102986 00000000
cégjegyzékszám: 06-09-014002
info:

Machine Application

Widely used in sheetmetal processing, aviation, aerospace, electronics, electrical appliances, automobile, food machinery, textile machinery, engineering machinery, precision parts, ships, metallurgy equipment, elevators, household appliances, craft gifts, tool processing, decoration, advertising, and other fields. Professional used to cut sheet metal like carbon/mild steel, stainless steel, aluminum alloy, galvanized sheet, electrolytic plate, titanium alloy, aluminum zinc plate, etc.

